

Technical Information

The ALLiON AL4830-GC2 is a high performance, 48V deep cycle lithium battery with a capacity of 30Ah. This battery has been designed as a lightweight, high cycle replacement for lead acid batteries in 48V applications such as golf carts and commercial cleaning equipment. A remote battery monitor and Bluetooth module are both available as optional accessories to enable remote monitoring of the battery status, including State of Charge. The integrated Battery Management System (BMS) ensures battery operation is safe and reliable over the life of the battery.

Features and Benefits

- Up to 6000 cycles at 80% DoD (@25°C)
- More usable capacity
- Lightweight
- Fast recharging
- IP67 rated case

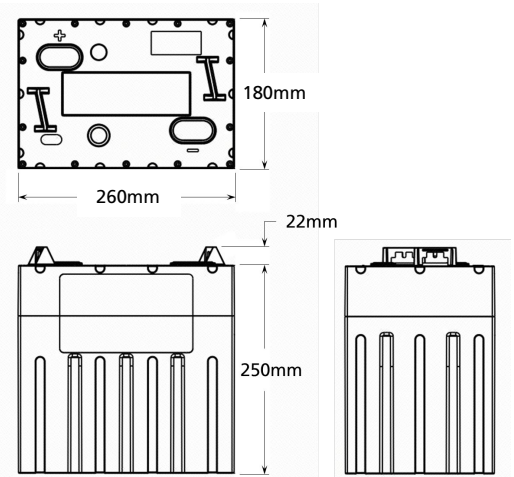

Applications

- Golf Carts
- Floor Scrubbing Machines
- Commercial Turf Equipment

Item	Characteristic		Specification
1.1	Nominal Capacity		30Ah
1.2	Nominal Energy		1.536kWh
1.3	Nominal Voltage		51.2V
1.4	Internal Impedance		≤ 50mΩ @ 1kHz AC
1.5	Nominal Charge Voltage		55.2 – 57.6V
1.6	Float Charge Voltage		54.4V
1.7	Maximum charge current		30A (1C)
1.8	Recommended charge current		9A (0.3C)
1.9	Maximum continuous discharge current		60A (2C)
1.10	Maximum peak discharge current		65A for 30 seconds, 100A for 10 seconds
1.11	Discharge cut-off voltage		44.8V
1.12	Dimensions (L x W x H), ±2mm		260mm x 180mm x 272mm
1.13	Nominal Weight		15.5kg
1.14	Bluetooth Connectivity		Yes, via optional Bluetooth module
1.15	Operating Temperature	Charge	0°C to +45°C
		Discharge	-20°C to +65°C
1.16	Self Discharge		≤ 3% /month, ≤ 15% /year
1.17	Storage Environment	≤ 1 month	-20°C to +60°C, 5% to 75% RH
		≤ 3 months	-10°C to +45°C, 5% to 75% RH
		Recommended	+15°C to +35°C, 5% to 75% RH
1.18	Parallel connection of up to 10 batteries is supported (refer to page 2). Individual battery voltages must be within 2V when connecting in parallel. Do not connect the batteries in series.		

Connecting Multiple Batteries

When connecting multiple batteries in parallel, ensure the voltage of all batteries is within 2V. The wire used to connect the batteries must be sized correctly to ensure it can support the maximum current flow of the device. It is good practise to use wire which one size larger than required to minimize any voltage drop.

The positive and negative wires of the parallel battery network must be connected from opposite ends. This balances any voltage drop for each battery and ensures that each battery contributes and is charged equally.

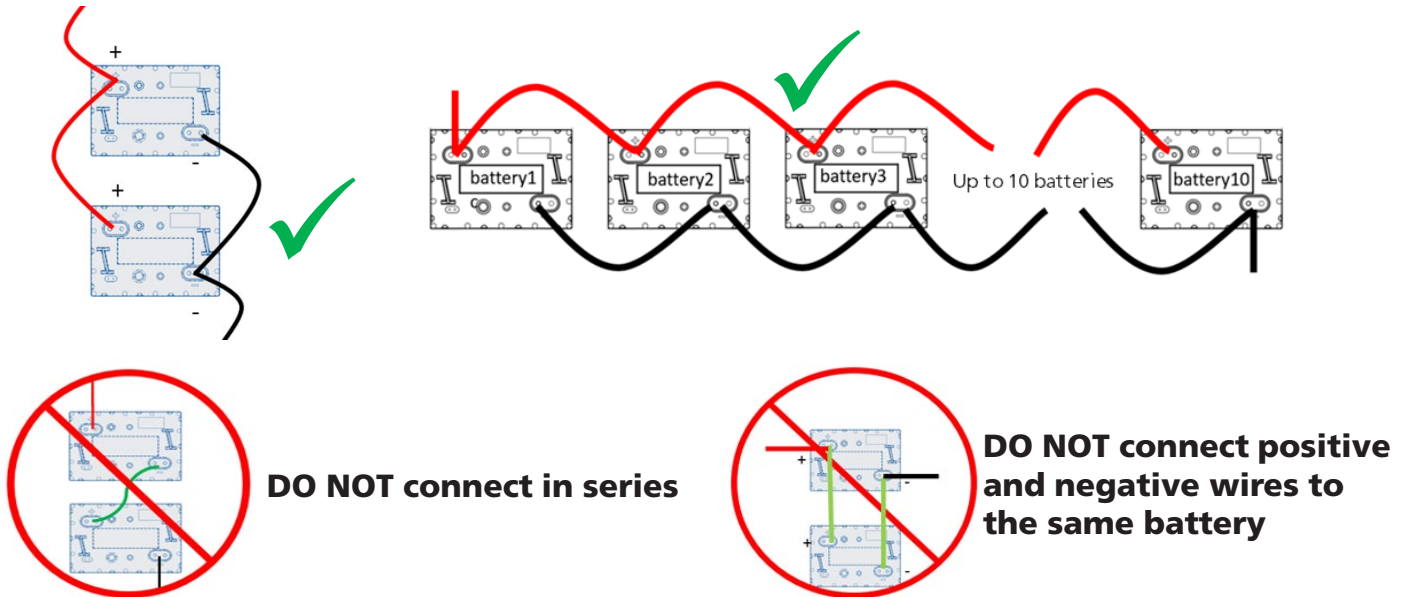

Product Safety

Storage & Transport

- The battery must be charged using the Standard Charge Process every 6 months if not in use.
- Do not drop the battery.
- Maximum stacking quantity (height) is 4 batteries.
- The battery must be kept upright at all times.

Product Warnings

Please read and follow the handling instructions before use. Improper use may cause heat, fire, rupture, damage or capacity deterioration of the battery. The manufacturer is not responsible for any accidents caused by misuse or poor maintenance.

- Do not store or use battery near heat source.
- Do not install in vehicle engine bay.
- Do not expose battery to direct sunlight for extended periods.
- Do not connect battery to high voltage.
- Do not place battery in water or fire.
- Always check polarity before connecting the battery.
- Do not short circuit battery.
- Do not expose the battery to impact or crushing force.
- Do not disassemble the battery.
- Protect battery from high temperatures. High temperatures may result in fire or loss of battery function and service life.
- Do not install or connect this battery with different battery types.
- Do not allow the battery to remain discharged.
- Use the correct battery charger for this battery.
- If battery emits an unusual odor, becomes hot or the case has distorted, stop using the battery immediately.
- If eyes or skin are exposed to liquid leaking from the battery, rinse it with clean water and seek medical advice immediately.