

Technical Information

The Predator PSB12-7.2 F1 is an Absorbent Glass Mat (AGM) battery with the narrower F1 spade terminals designed for general purpose & standby applications including UPS, communication & security systems.

The Predator PSB is manufactured in a facility which is ISO 9001, ISO 14001 & OHSAS 18001 certified. The valve regulated, non-spillable design delivers outstanding cycle life and a low self discharge rate resulting in a 6-8 year design life.

For deep cycle applications, the Predator ED series is recommended.

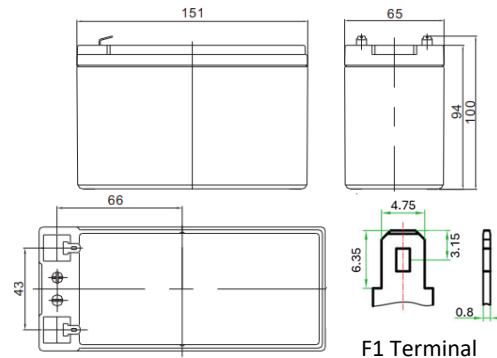

Life Expectancy - Standby Use

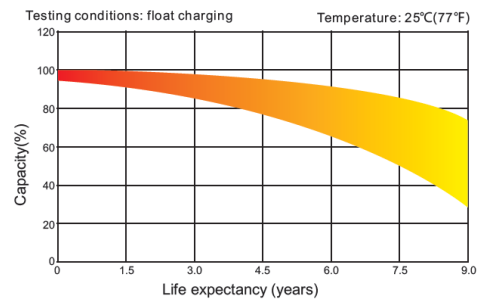

Features & Benefits

- Heavy Duty, Non-Spillable Design
- AGM Construction
- Improved Energy Density & Service Life
- Low Self Discharge
- 6-8 years design life @ 25°C

Applications

- Uninterruptible Power Supply (UPS)
- Security Systems
- NBN Backup

Technical Specifications

Battery Type	General Purpose AGM	Case Material Colour	ABS Black Case, Black Lid
Voltage	12V	Charge Current	Recommended: 0.7A Maximum: 2.1A
Capacity (20 / 10 / 5 / 3Hr)	7.20 / 6.73 / 6.20 / 5.51Ah	Charge Voltage	14.6 – 14.8V @ 25°C (Temp. Coeff. -24mV/°C)
Internal Resistance (25°C)	Approx. 35.0m	Float Voltage	13.7 – 13.9V @ 25°C (Temp. Coeff. -18mV/°C)
Overall Size (LxWxH ±2mm)	151 x 65 x 100mm	Operating Temp. Charge	0 to 50°C
Nominal Weight	1.95kg	Operating Temp. Discharge	-20 to 60°C

Battery Finder

More in Predator Range

Contact Us