

Technical Information

The Predator PDC12-120 is a true deep cycle Absorbent Glass Mat (AGM) battery.

This battery is built by an ISO certified manufacturer and features a unique active material formula, double sealed terminals and a high strength ABS plastic case.

The terminal design and location allows for easy installation and access. A unique one-way vent valve design controls gassing, making it a true maintenance free deep cycle battery. The excellent deep cycle performance makes this battery an ideal solution for many applications including caravan/camper and marine systems.

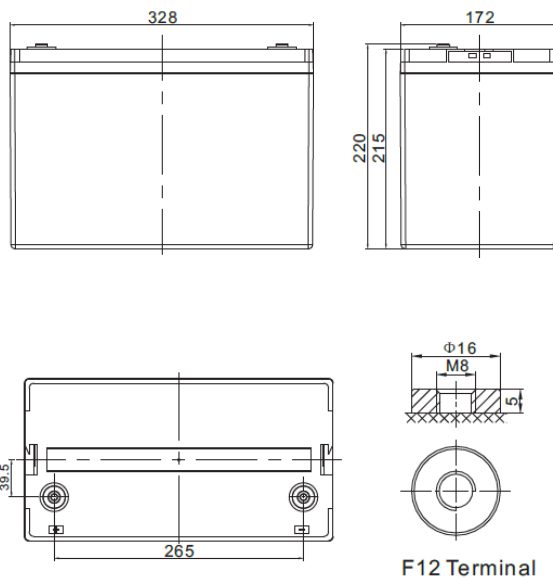

Features & Benefits

- Heavy Duty, Non-Spillable Design
- True Deep Cycle AGM Technology
- Low Self Discharge
- High Vibration Resistance

Applications

- Marine Auxiliary Power
- Mobility/Medical equipment
- Caravan/Camper Power
- 4WD/SUV/RV Auxiliary Power

Technical Specifications

Battery Type	Deep Cycle AGM	Case Material	A.B.S. UL94-HB
Voltage	12V	Lid Type / Colour	Maintenance Free / Black
Capacity (20Hr / 5Hr)	120Ah / 103Ah	Plate Type	Cast Grids
Max. Discharge Current	1200A (5 sec)	Separator Type	Absorbent Glass Mat
Max. Charging Current	36A	Assembly Layout	LH Positive [+ -]
		Terminal Type	M8 threaded insert
Overall Size (LxWxH)	328 x 172 x 220mm	Case Size	BCI Group 31
Nominal Weight	29kg	Ledges	None

Charging

Absorb Voltage: 14.7±0.1V
 Recommended Charge Current: 6-12A
 Maximum Charge Current: 36A

Temperature Compensation:
 Cycle use -4mV/°C / Cell
 Float use -3mV/°C / Cell

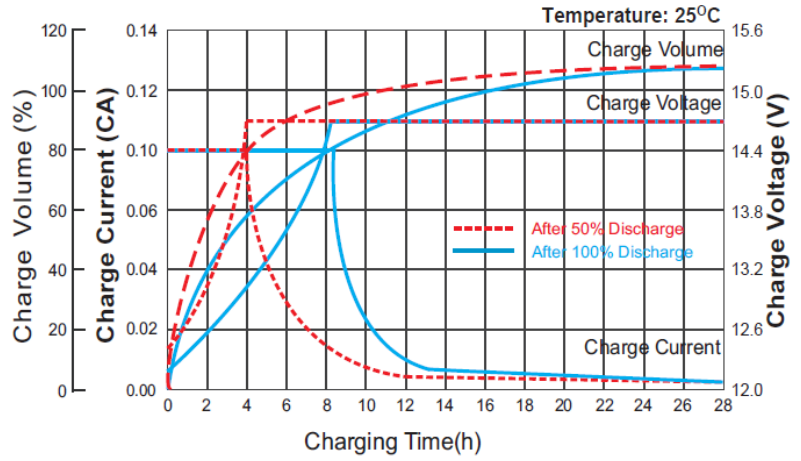

Performance Characteristics

Discharge Characteristics Curve

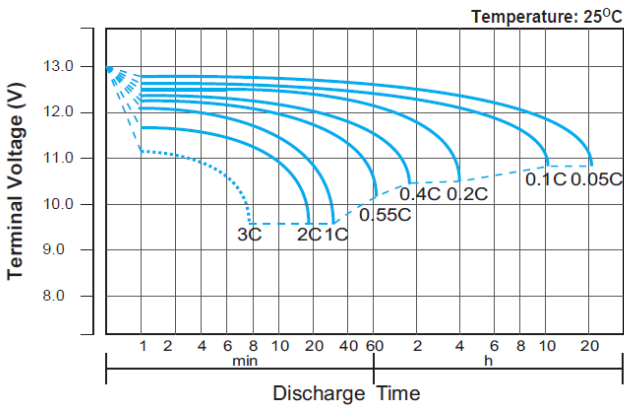

Cycle Life vs Depth of Discharge

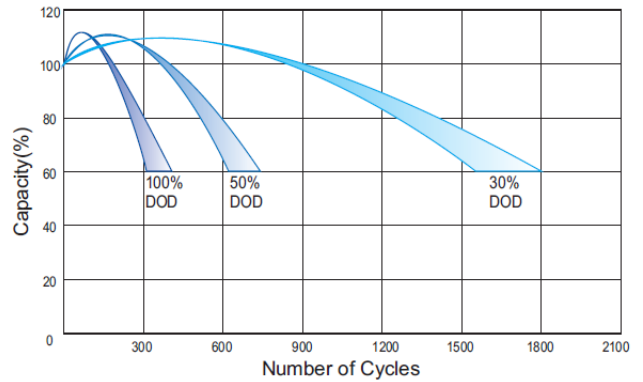

Charge Voltage vs Temperature

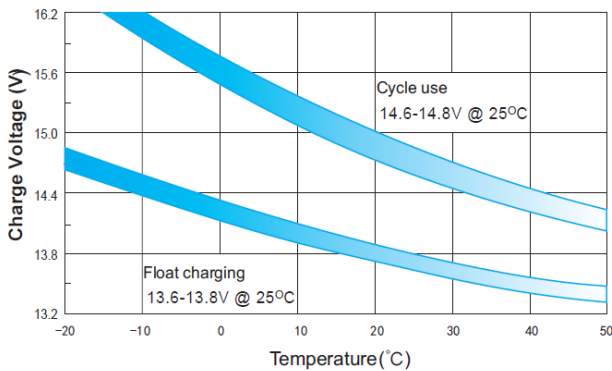

Open Circuit Voltage vs State of Charge

