

Technical Information

The Delkor 100D-730 is a custom military-spec battery designed for army tanks, Unimogs and other military / off-road vehicle applications.

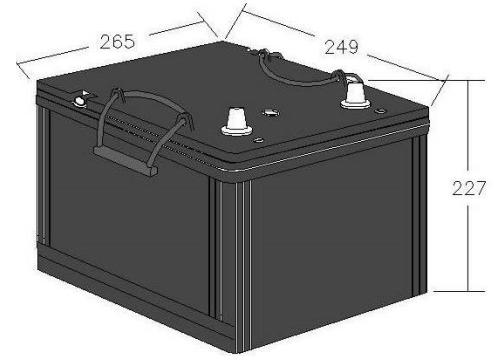

Features and Benefits

- Renowned Delkor quality
- Sealed Maintenance-Free
- Unique design for specific Unimog and military applications
- Strong, durable wrought grid plate design
- Lock-bonded elements for added durability and strength

Applications

- Unimog (Mercedes-Benz)
- Army tanks
- Military applications
- Oka 4WD truck
- Custom applications

Technical Specifications

Battery Type:	Sealed Maintenance-Free	Container Material / Colour:	Polypropylene / Black
Voltage:	12	Lid Type / Colour:	Sealed / Black
Capacity (@20hr rate):	100	Plate Type:	Commercial-grade Lead-Calcium + Tin
Cold Cranking Amps -18°C, SAE:	730	Separator Type:	PVC Envelope
Cold Cranking Amps – 0 Deg. C	850	Anti-Vibration:	Lock-bonded plate elements
Reserve Capacity:	185 Min.	Assembly Layout:	RHP
Overall Dimensions:	265L x 249W x 227TH	Terminal Type:	SAE
Wet Battery Weight:	25.5kg	BCI Group:	6TN

WARRANTY: 12 MONTHS.

Normal Delkor commercial battery warranty conditions apply. Refer to Delkor warranty statement for more information.